

FAB-HGT-16A Fiber Termination Box-16 Cores



Description:

Fibramérica's Fiber Termination Box provides a high density wall mounted solution for next generation networks, which aims to provide and manage maximum numbers of fiber termination in a limited space. It is normally installed in the way of wall mounting or pole mounting.

Features:

1. Water-proof design with IP65 Protection level
 2. Integrated with splice cassette and cable management system
-
-

3. Manage small & large quantities of fiber with a density
4. Easy to maintain and extend the capacity
5. Fiber bend radius control more than 40mm
6. Suitable for the fusion splice or mechanical splice
7. Capacity of fiber up to 16 ports
8. Varies of adapters are available
9. 1×8, 1×16 PLC Splitter can be installed as an option
10. Efficient cable management
11. UV protection and anti-aging material
12. Burglar-proof padlock

Configuration:

Material	Size	Max Capacity			Empty Weight	Loaded Weight	Color
		SC	LC	PLC			
PC+ABS	A*B*C(mm) 293*219*84	16 Ports	32 Ports	1x8/1x16	1.4kg	1.8kg	White/ Black

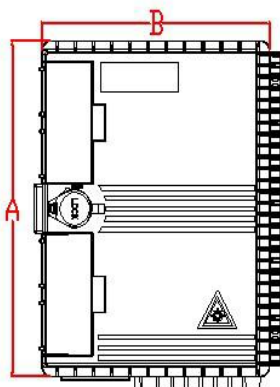

Pic 1 Box Size

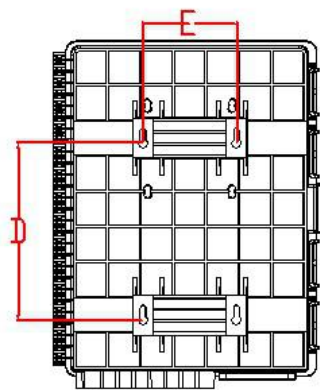
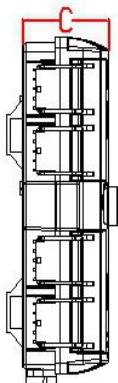

Pic 2 Installation Size

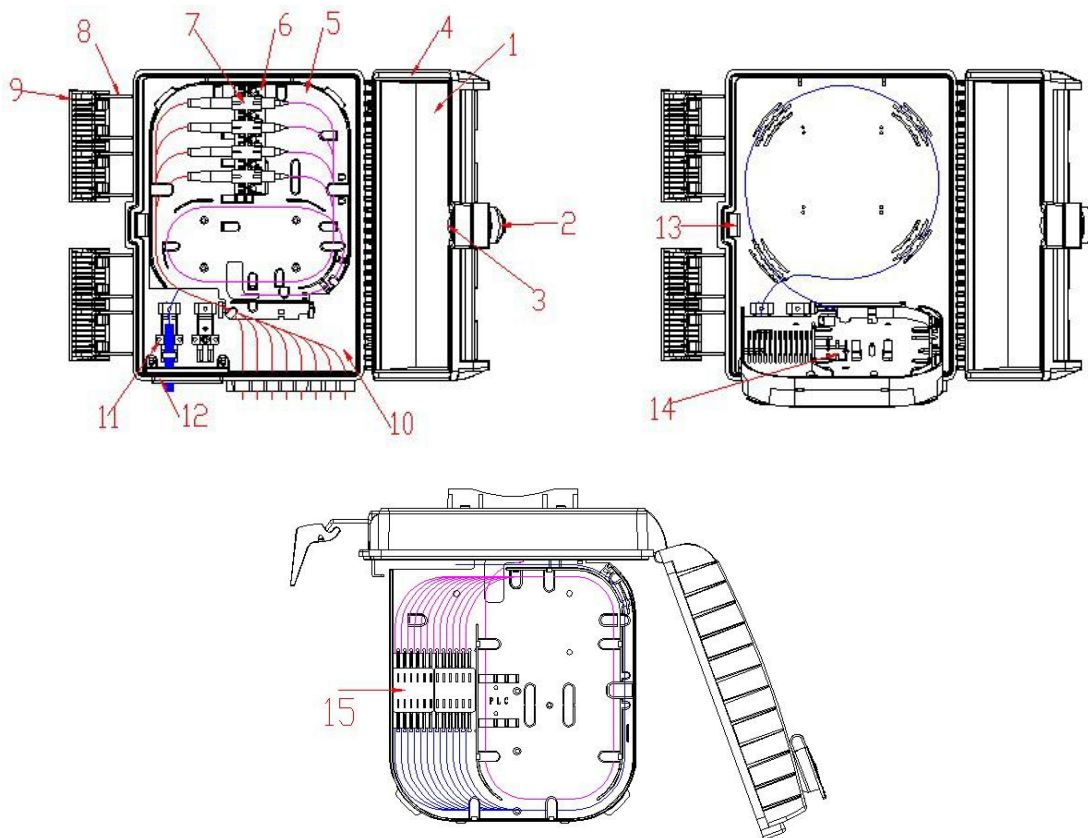
Product cable ways:

Installation:

1. Wall-mounted installation

Drill 4 holes over the wall based on the size in table 1, place the expansion bolt $\Phi 7.5 \times 40$, place the box to match up the holes and use bolt to fasten.

2. Pole-mounted installation

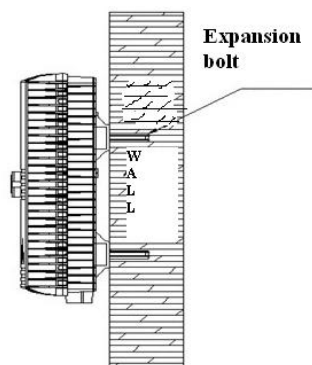
Fix 1 set of the easy pole ring to the telecom pole.



Wall mounted installation

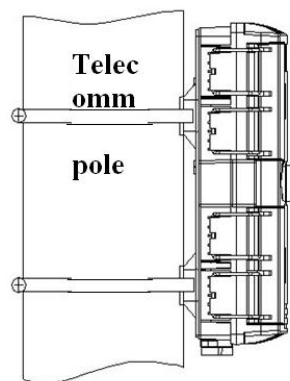

Pole ring installation

Accessories:

1. Users' Manual*1
 2. Key*1
 3. Accessories Bag * 1
 5. Easy pole ring*2, M6*20mm Bolt*2 (Option)
-
-